

24 PAX OFFSHORE SUPPORT VESSEL SEAZIP 8



A highly flexible support vessel designed to perform a wide range of offshore wind farm servicing tasks, in adverse and demanding environments. All SeaZip vessels are fitted with the latest and most reliable vessel management systems for safety, passenger comfort and reliability.

GENERAL

Vessel type	Catamaran
HSC	Yes
Hull material	Aluminium
Crew	3
Transfer crew	24 (12 PAX + 12 Industrial Personnel or 24 Industrial Personnel)
Flag	Dutch
Classification	Bureau Veritas
IMO	9831969
Year of Build	2018

MAIN PARTICULARS

Length Over All (LOA)	27.40 m
Length hull	24.95 m
Beam moulded	8 m
Extreme draught	1.46 m
Maximum deadweight (approx.)	30.00 t
Maximum cargo	20.00 t
Light ship displacement	76 t
Gross Tonnage	106.6 t

TANK CAPACITIES

Fresh water tank	3.00 m ³
Black/Grey water tank	3.00 m ³
Fuel transfer capability	130 l/min @ 20 m lift
Fuel capacity	25000 l

OPERATIONAL PARTICULARS

Speed @ 85% MCR (10t deadweight)	Max. 22 kts
Speed (10t deadweight)	Max. 25 kts
Engines	2 x MAN D2862 LE463, 2058 kW
Propulsion	2 x Hamillton HM651 jets

DECK CAPACITIES

Fore deck	2 x 10 ft containers
Cargo area	11.5 m ²
Cargo area foredeck	35.9 m ²
Deck load	2 t/m ²
Deck crane	Palfinger PK 8501 MSWL 1.200 kgs @ 5 m, turning on around 410°, local control, storage at sea support.
Fender	RG Seasight

NAVIGATION & COMMUNICATION EQUIPMENT

Crewfinder system corresponding to the PLB's (Personnel Locator Beacons) used on site	Yes
GPS	Yes
NAVTEX	Yes
Radar reflector	Yes
Automatic identification system (AIS) class A	Yes
Propeller RPM or thrust indicator	No
RPM for engine	Yes
Rudder angle indicator (or direction of steering thrust)	Yes
GHz Radar with plotting function	Yes
Echo sounding device	Yes
Speed and distance measuring device capable of measuring speed through the water	Yes
Satellite compass	Yes
A fixed mounted magnetic compass, properly adjusted with deviation table	Yes
Compressed-air horn	Yes
GMDSS Radio equipment	Yes
Handheld VHF for deck personnel	Yes, 2
VHF with DSC & P-channel as advised by site	Yes, 2, see above
Emergency Position Indicating Radio Beacon (EPIRB)	Yes
Search and Rescue Transponder (SART)	Yes



ACCOMMODATION ARRANGEMENT

Seating type	KPM
	crew 100
Seating number	24 IP
Storage	250 l
under each passenger seat	
Mess/Pantry and toilet/shower	Yes
Dry baggage storage	Yes
Wet changing room	Yes
Dangerous good area on fore deck	Yes
HVAC	Yes

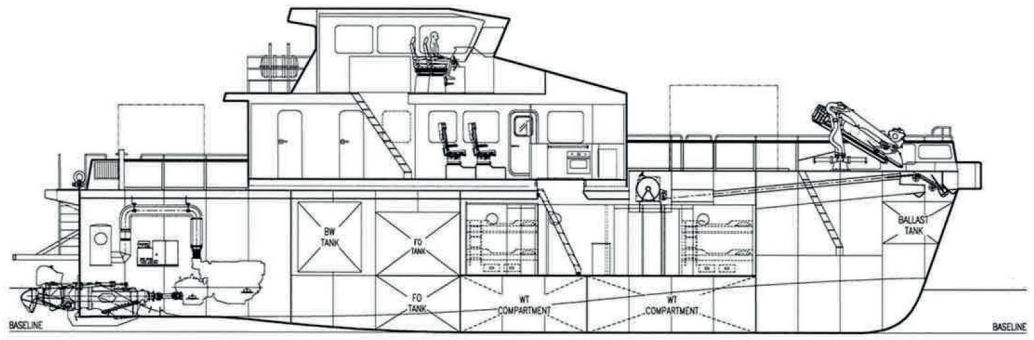

FIRE FIGHTING APPLIANCES

The Vessel shall be provided with a fire main designed to meet the Class requirements and the relevant regulatory body.

LIFE SAVING

Lifesaving equipment shall be in accordance with Flag requirements for vessel area of operation and quantity of 27 persons.

Life rafts	2 x 35 people, SOLAS Pack A in containers with hydrostatic release
Life jackets	30
Immersion suits	3
Thermal protective aids	2
Life buoys with lights	2
Life buoys with buoyant line	2
Approved throwing line	1
Pyrotechnics	1 set
Scramble net	1, integrated inside bulwark

In addition a Man-over Board (MOB) rescue facility is included, consisting of 1 recovery davit positioned on starboard side of vessel, with a 'mate saver' or similar recovery device.

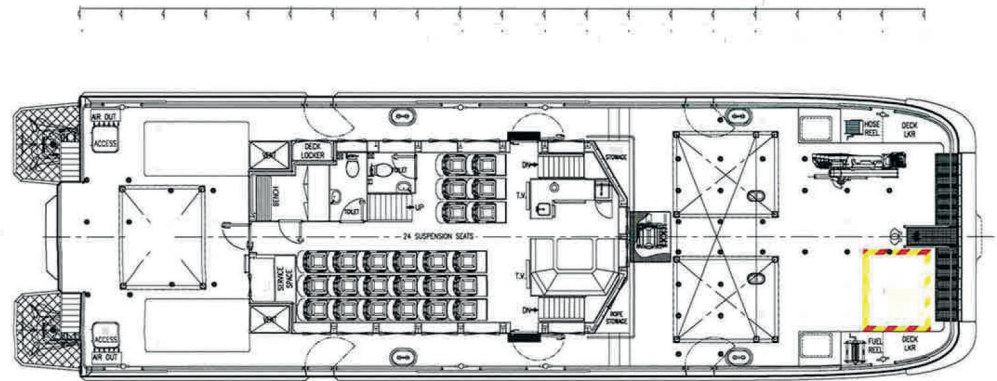
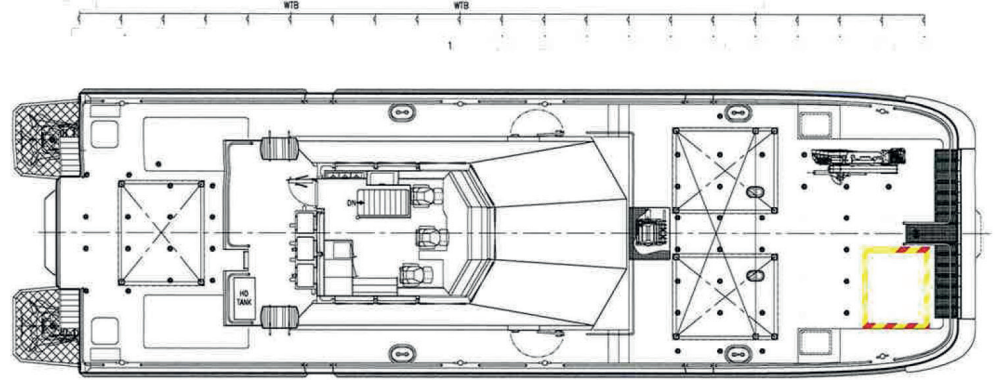

ADDITIONAL FEATURES / REMARKS

Vessel Motion Monitoring System	Yes
CCTV monitoring and recording of operations	Yes

Some of the items in this specification are optional. Specification and general arrangement can be changed without notice.

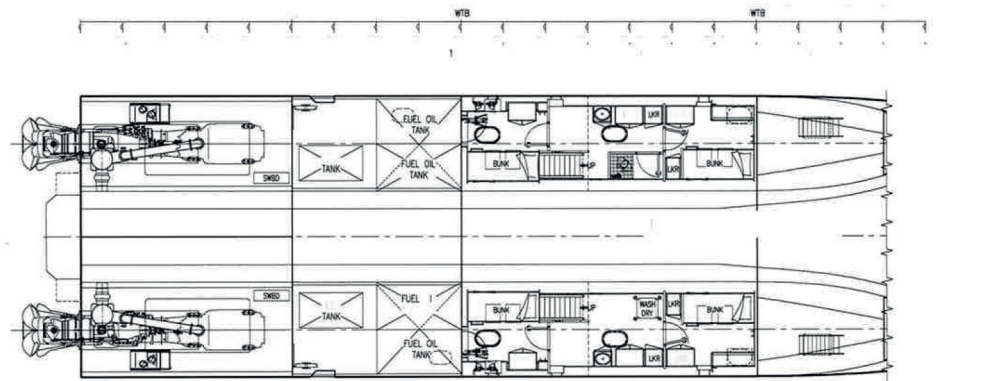

ABOUT THE SHIP MANAGER

The management of SeaZip vessels is carried out by the JR Shipping Group in Harlingen, The Netherlands, an experienced and all-round shipping company.

The shipping group operates a fleet of modern container feeders sailing under Dutch flag. JR Shipping cooperates closely with experienced maritime partners, several shipyards in the Netherlands and abroad, and renowned shipping bankers. JR Shipping is an efficient, flexible organisation, offering swift and effective solutions. We combine clout in ship development with well-secured quality and safety in ship management and an eye for sustainability.

www.jrshipping.com

SEAZIP
OFFSHORE SERVICE

HIGH PERFORMANCE, SAFE OFFSHORE OPERATIONS



Korte Lijnbaan 25
P.O. Box 3, 8860 AA Harlingen
The Netherlands

T + 31(0)517 431 225
info@seazip.com
www.seazip.com